

# INSTRUCTIONS-PARTS LIST



802-776

Rev A

This manual contains **IMPORTANT**  
**WARNINGS** and **INSTRUCTIONS**  
READ AND RETAIN FOR REFERENCE

## **HYDRA-CLEAN 826** **Pressure Washer**

P/N 800-232 SERIES "A"

*800 psi (55 bar) OPERATING PRESSURE*

*1100 psi (76 bar) MAXIMUM WORKING PRESSURE*

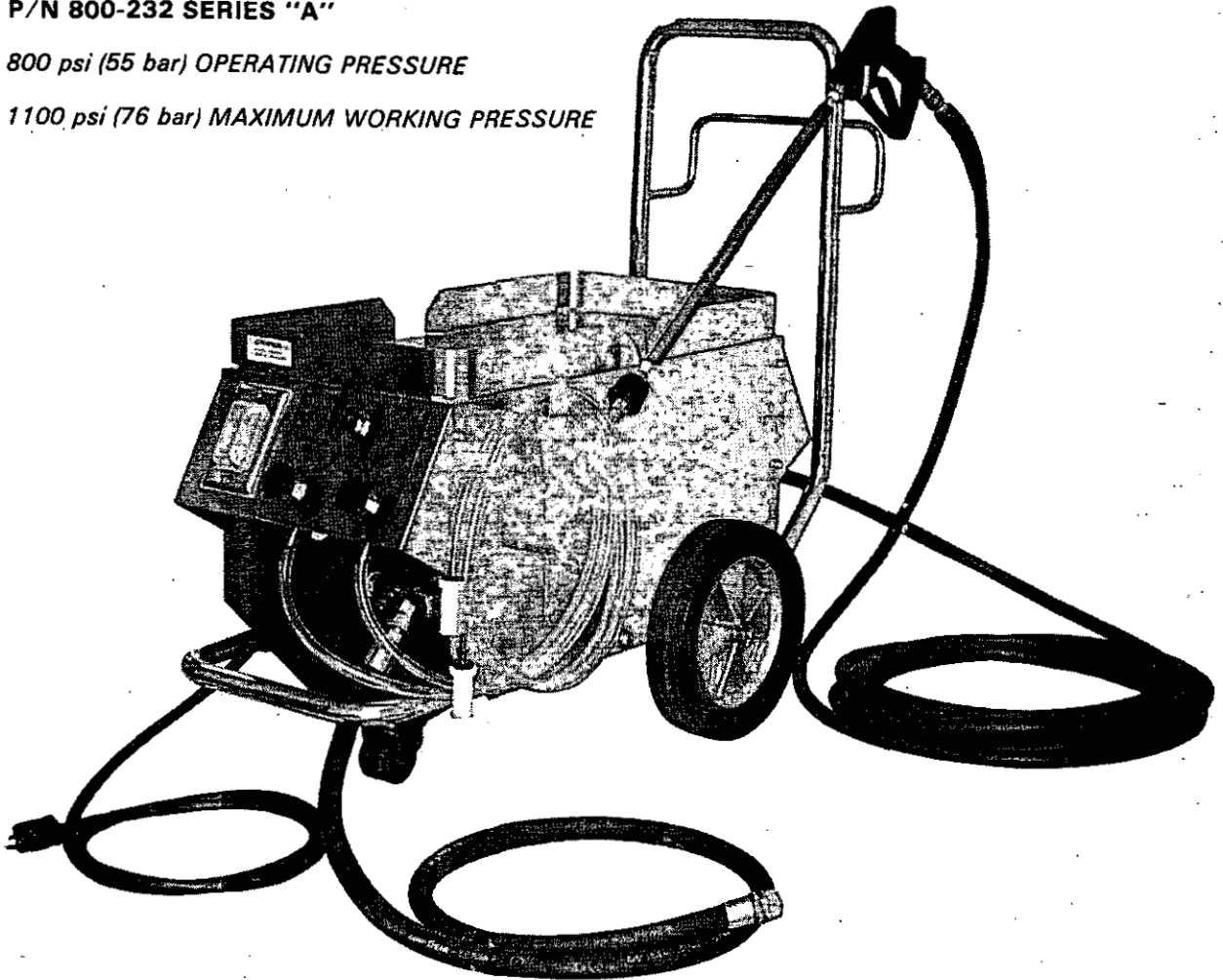

**GRACO INC. P.O. Box 1441 MINNEAPOLIS, MN 55440-1444**

©COPYRIGHT 1987 GRACO INC.

# WARNING

**HIGH PRESSURE SPRAY CAN CAUSE SERIOUS INJURY.  
FOR PROFESSIONAL USE ONLY. OBSERVE ALL WARNINGS.**

Read and understand all instruction manuals before operating equipment.

## FLUID INJECTION HAZARD

### General Safety

This pressure washer generates very high fluid pressure. Spray from the gun, leaks or ruptured components can inject fluid through your skin and into your body and cause extremely serious bodily injury, including the need for amputation. Also, fluid injected or splashed into the eyes or on the skin can cause serious damage. In addition, some cleaning solutions may be toxic and can cause chemical burns, skin irritations, and allergic reactions if inhaled or if they come in contact with the body or eyes. Always follow these precautions when operating your pressure washing system to reduce the risk of serious bodily injury.

NEVER point the spray gun at anyone or at any part of the body. NEVER use the spray gun without the wand. NEVER put hand or fingers over the spray tip.

NEVER try to stop or deflect leaks with your hand or body.

ALWAYS be sure equipment safety devices are operating properly before each use.

Use this pump only for pumping water and water-diluted cleaning solutions. NEVER use the pump for paint or any other coatings.

ALWAYS wear protective eyewear and appropriate clothing to protect yourself from the overspray and the debris that is removed as you clean.

Read and follow the cleaning chemical manufacturer's recommendations on preparation and use of the cleaning solution, and the use of breathing apparatus and proper ventilation.

### MEDICAL TREATMENT

If any fluid appears to penetrate your skin, get **EMERGENCY MEDICAL CARE AT ONCE. DO NOT TREAT AS A SIMPLE CUT.** Tell the doctor exactly what fluid was injected.

*Note To Physician: Injection in the skin is a traumatic injury. It is important to treat the injury surgically as soon as possible. Do not delay treatment to research toxicity. Toxicity is a concern with some exotic coatings injected directly into the blood stream. Consultation with a plastic surgeon or reconstructive hand surgeon may be advisable.*

### Pressure Relief Procedure

To reduce the risk of serious bodily injury, including fluid injection and splashing in the eyes, or on the skin, always follow this procedure whenever you shut off the pump, when checking or servicing any part of the system, when installing or changing spray tips, and whenever you stop spraying for more than 10 minutes.

1. Engage the gun trigger safety latch.
2. Turn pressure washer OFF.
3. Remove the power cord from outlet.
4. Shut off the water supply.
5. Disengage the trigger safety latch and trigger the gun to relieve pressure, and engage the latch again.

### Spray Gun Safety

Do not remove or modify any part of the gun; this can cause a malfunction and result in serious bodily injury.

### Safety Latch

ALWAYS engage the gun safety latch whenever you stop cleaning, even for a moment. The latch **MUST BE** pushed fully down to make the gun inoperative. Failure to properly set the safety latch can result in accidental triggering of the gun. See Figure 2, page 6.

### Spray Tip Safety

Use extreme caution when cleaning or changing spray tips. If the spray tip clogs while spraying, engage the gun safety latch immediately. ALWAYS follow the **Pressure Relief Procedure** and then remove the spray tip to clean it.

## **EQUIPMENT MISUSE**

### **HAZARD**

#### **General Safety**

Any misuse of the pressure washer or accessories, such as overpressurizing, modifying parts, using incompatible chemicals and fluids, or using worn or damaged parts, can cause them to rupture and result in fluid injection, splashing in the eyes or on the skin, or other serious bodily injury or property damage.

NEVER alter or modify any part of this equipment, doing so could cause it to malfunction.

CHECK all cleaning equipment regularly and repair or replace worn or damaged parts immediately.

If using a chemical injector, read and follow the chemical manufacturer's literature regarding the use of protective eyewear, clothing and equipment.

#### **System Pressure**

This sprayer can develop 1100 psi (76 bar) MAXIMUM WORKING PRESSURE. Be sure that all spray equipment and accessories are rated to withstand the maximum working pressure of this sprayer. DO NOT exceed the maximum working pressure of any component or accessory used in the system.

#### **Chemical Compatibility**

BE SURE that all chemicals used in the chemical injector are compatible with the wetted parts of the hose, gun, wand and tip, as given in the Technical Data on the back cover. Always read the chemical manufacturer's literature before using any chemical in this pressure washer.

### **HOSE SAFETY**

High pressure fluid in the hoses can be very dangerous. If the hose develops a leak, split or rupture due to any kind of wear, damage or misuse, the high pressure spray emitted from it can cause a fluid injection injury or other serious bodily injury or property damage.

TIGHTEN all fluid connections securely before each use. High pressure fluid can dislodge a loose coupling or allow high pressure spray to be emitted from the coupling.

NEVER use a damaged hose. Before each use, check entire hose for cuts, leaks, abrasion, bulging cover, or damage or movement of the hose couplings. If any of these conditions exist, replace the hose immediately. DO NOT try to recouple high pressure hose or mend it with tape or any other device. A repaired hose cannot contain the high pressure fluid.

HANDLE AND ROUTE HOSES CAREFULLY. Do not pull on hoses to move the pressure washer. Do not use chemicals which are not compatible with the inner tube and cover of the hose. DO NOT expose Graco hose to temperatures above 200°F (94°C) or below -40°F (-40°C).

### **ELECTRICAL HAZARD**

NEVER operate the pressure washer without the unit being properly grounded. This includes internal wiring on unit, plug (ground plug must be intact), and building wiring. Because water is a natural conductor, it is very important to provide a good ground circuit to avoid serious bodily injury if equipment should fail.

### **MOVING PARTS HAZARD**

Moving parts can pinch or amputate your fingers or other body parts. KEEP CLEAR of moving parts when starting or operating the pressure washer. Follow the Pressure Relief Procedure, page 2, before checking or servicing the pressure washer to prevent discharging high pressure fluid from the gun.

### **IMPORTANT**

United States Government safety standards have been adopted under the Occupational Safety and Health Act. These standards—particularly the General Standards, Part 1910, and the Construction Standards, Part 1926—should be consulted.

### **TERMS**

**WARNING:** Alerts user to avoid or correct conditions that could cause bodily injury.

**CAUTION:** Alerts user to avoid or correct conditions that could cause damage to or destruction of equipment.

**NOTE:** Identifies helpful procedures and information.

## ASSEMBLY/INSTALLATION

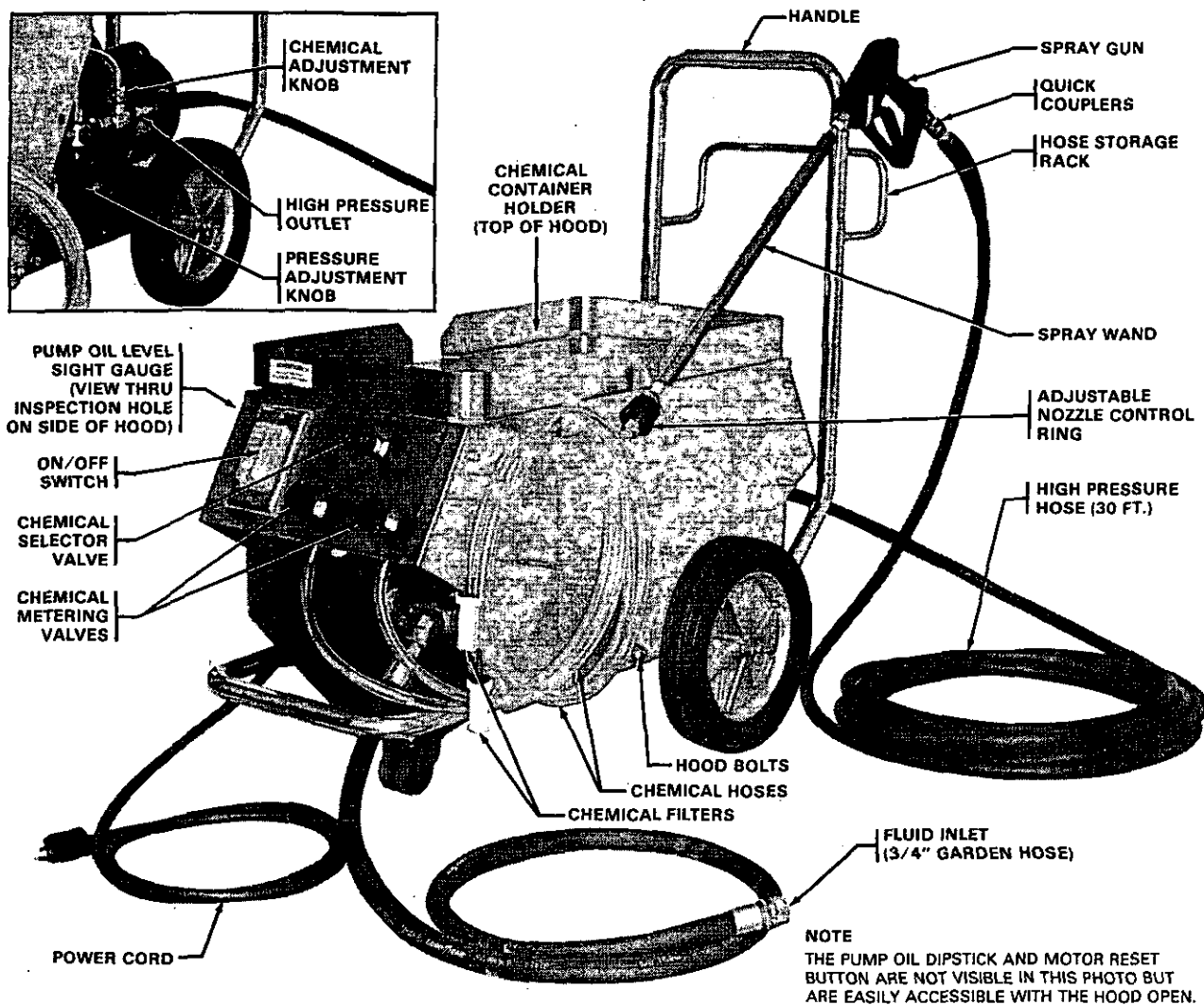

FIGURE 1

## SET-UP

1. Remove the two hood bolts, flats and locks, from the center bottom of each side of the hood. Pivot the hood open.
2. Position the handle into the end of the chassis closest to the wheels. Line up the four mounting holes. Install the four 3/8 x 1 inch bolts from the outside of the chassis. Use flat washers only on head of bolt. Use a flat washer, lock washer, and nut on each bolt on the inside of the chassis.
3. Connect one end of the 30 foot high pressure hose to the pump outlet. This connection is made with a threaded swivel fitting. Connect the other end to the gun using the quick couplers provided.

### CAUTION

Up to 90 feet of high pressure hose may be used. Using longer hoses may affect sprayer performance, and chemical injector performance.

4. Remove the plastic plug from the top of the pump and install the dipstick.

**NOTE:** The plastic plug may be reused to prevent splashing oil when transporting the pressure washer in a vehicle. Be sure to reinstall the dipstick before using the unit to allow proper venting.

5. Hood may now be closed and secured with hood bolts, flat washers, and lock washers removed in Step 1.
6. Remove the plastic plug from the inlet hose. Check the water supply flow rate (see page 5). Connect inlet hose to water supply. A standard 5/8 I.D. garden hose may be used to connect inlet hose to the water supply.

## Water Supply

### CAUTION

Before connecting the water supply to the pump, check your local plumbing code regarding cross-connection to the water supply.

A backflow preventor, Part No. 801-133, is available to prevent the back flow of contaminated water into the fresh water supply. Install upstream from the pump.

DO NOT exceed 160°F (70°C) inlet water temperature.

Higher temperatures will damage the pump packings.

- A. Check flow rate of the water supply. It must be at least 3 gpm or the pressure washer will not develop full pressure.
- B. To check flow rate, time how long it takes to fill a standard five gallon pail; it should take no longer than 1 minute and 40 seconds.

## Electrical Supply

7. Connect the power cord to the proper power supply. The electrical service required is single phase, 115V, 60 Hz AC, 15 Amp. Electrical service must include a ground wire. If an extension cord is used, it must have a ground wire and be at least No. 14 gage wire. Extension cord must not be over 100 feet long.

## START-UP

Use this procedure each time you start the pressure washer to help ensure the pressure washer is ready to operate and that you start it safely.

1. Check pump oil level. Look at oil level indicator window through inspection hole in side of the hood. Pump also has a dipstick located under hood on top of pump. Oil level should be up to dot on oil level indicator window and within the notch on dipstick. Add SAE 20 or 30-weight non-detergent oil as necessary.
2. Connect pressure washer to water supply and to proper electrical service as described in set-up.
3. Turn water supply on and trigger the gun until water sprays from the tip and all air is purged from the system.
4. Press start button on control panel.

**NOTE:** Avoid pressing start button when unit is not plugged in because the stop button cannot be pushed unless unit is plugged in. Always use motor control switch when starting and stopping unit.

5. Always engage the gun's trigger safety latch whenever you stop spraying, even for a moment, to reduce the risk of fluid injection or splashing in the eyes or on the skin if the gun is bumped or triggered accidentally.
6. Most pressure washer spraying is done at full pressure. If a reduced pressure is desired for a special application, there are two methods to reduce the maximum output from the pressure washer.
  - a. Turn the pressure control knob on the unloader counterclockwise, as needed. This method is best if you are operating consistently at a reduced pressure.

- b. Turn chemical selector valve to the "OFF" position, then open the adjustable nozzle on the end of the spray wand, as needed. This method is best to quickly reduce pressure for a special application.

### WARNING

DO NOT attempt to adjust the adjustable nozzle when the spray gun is in use. Be sure that the safety latch on the gun is in the "ON" position before adjusting to avoid serious bodily injury or fluid injection.

7. Always observe the following cautions to help avoid costly damage to your pressure washer.

### CAUTION

DO NOT allow the pressure washer to idle for more than 10 minutes. The unit is equipped with a thermal relief valve to help avoid the recirculating water from becoming too hot and seriously damaging the pump, but it is a good idea to turn the pressure washer off if you are not spraying or cleaning at least every 10 minutes.

DO NOT run the pump dry, which will quickly damage the pump. Be sure the water supply is fully turned on before starting the pump.

DO NOT operate the pressure washer with the inlet screen removed. This screen helps keep abrasive sediment out of the pump, which could clog or scratch the pump.

DO NOT pump caustic materials; such materials may corrode the pump components.

## Chemical Injector Operation

8. Be sure that the control ring on the injector is open two full turns from the closed position. To check this, the hood must be opened. Once the control ring is open, it may be left alone. The chemical mixture is controlled by the chemical metering valves on the control panel.
9. Place the chemical strainer(s) and chemical line(s) into your chemical container(s).
10. Select which chemical you want to use with the chemical selector valve on the control panel.
11. To apply the cleaning chemical to the work surface, the adjustable nozzle on the end of the spray wand must be open. The chemical(s) can only be drawn into the water stream, and applied to the work surface in a low pressure situation. By opening the adjustable nozzle you create low pressure. Closing it produces high pressure for rinsing and pre-chemical flushing or no chemical cleaning. One chemical may be turned off and on at the gun by using the adjustable nozzle as described above.

### WARNING

DO NOT attempt to adjust the adjustable nozzle when the spray gun is in use. Be sure that the safety latch on the gun is in the "ON" position before adjusting to avoid serious bodily injury or fluid injection.

12. Adjust the chemical mixture(s) with the chemical metering valve(s) on the control panel. Once the chemical metering valve(s) are adjusted to the desired setting, they may be left there for future chemical applications.
13. To change to the other chemical, turn the chemical selector valve to the other chemical. To shut off chemical, turn the chemical selector valve to the "OFF" position, or close the adjustable nozzle. The chemical metering valve(s) do not have to be closed to change or shut off chemical supply.

### CAUTION

The chemicals used must be compatible with the wetted parts shown in the technical data at the end of this manual to avoid serious damage to the pressure washer and components.

## Trigger Safety Latch

### WARNING

To reduce the risk of serious bodily injury, including fluid injection, splashing in the eyes or on the skin, ALWAYS engage the trigger safety latch whenever you stop spraying, even for a moment.

In the engage position, the trigger safety latch prevents the gun from being triggered accidentally by hand or if it is dropped or bumped. Be sure the latch is fully seated in slot in handle or it cannot prevent the gun from being triggered. See Figure 2.

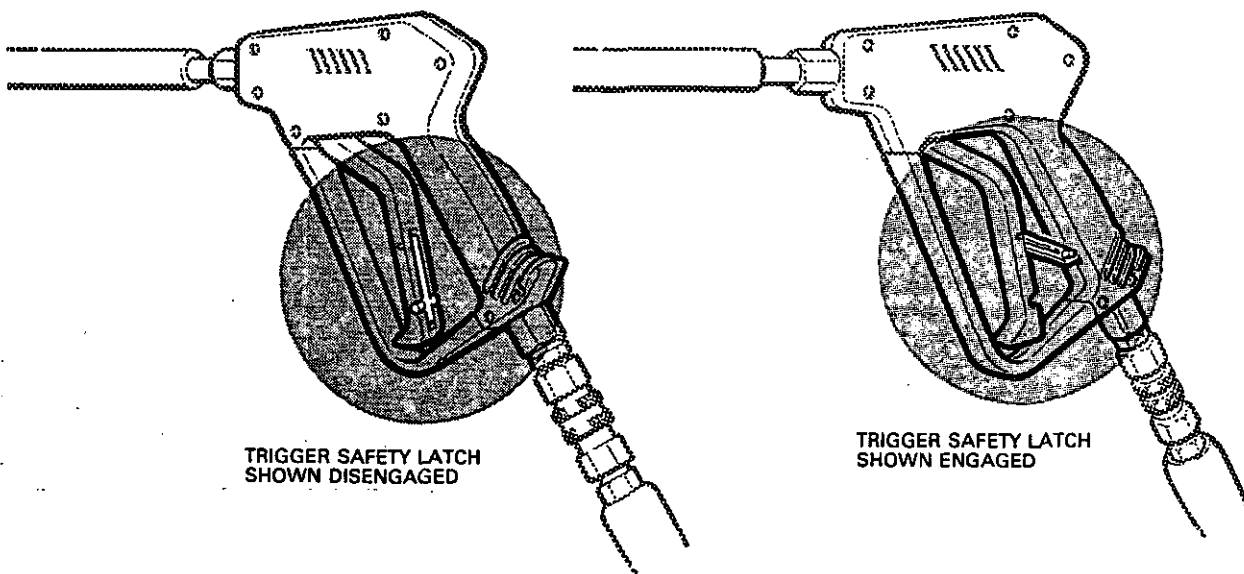

FIGURE 2

## SHUTDOWN, FLUSHING, AND STORAGE

### WARNING

#### Pressure Relief Procedure

To reduce the risk of serious bodily injury, including fluid injection and splashing in the eyes, or on the skin, ALWAYS follow this procedure whenever you shut off the pump, when checking or servicing any part of the system, when installing or changing spray tips, and whenever you stop spraying for more than 10 minutes.

1. Engage the gun trigger safety latch.
2. Turn the pressure washer off.
3. Remove the power cord from the outlet.
4. Shut off water supply.
5. Disengage the trigger safety latch and trigger the gun to relieve pressure, and engage latch again.

1. After using the chemical injector system, it should be flushed out with water or a 50% antifreeze solution if unit will be exposed to freezing temperatures. This is best done by replacing the chemical container(s) with a bucket of water or a 50% antifreeze solution. Operate pressure washer as described in start-up. Draw water or antifreeze solution into both chemical lines until it passes through the injector. By flushing the chemical injector system, you will help avoid unnecessary wear and prolong the life of components.

2. If the pressure washer will be exposed to freezing temperatures, drain all water out of the pump. If you must store the pressure washer in freezing temperatures, flush it with a 50% antifreeze solution. This can be done by placing the end of the inlet hose into a bucket of 50% antifreeze solution. Start the pressure washer. Trigger the gun for 10 seconds, release the trigger for 10 seconds. Trigger and release about 10 times or until the 50% antifreeze solution comes out of the spray tip.

### CAUTION

If water does freeze in the pressure washer, thaw it in a warm room before trying to start it. Do not pour hot water on the pump; it may crack the ceramic plungers!

3. After each use, wipe all surfaces of the pressure washer with a clean, damp cloth.
4. Perform the appropriate maintenance. See the chart on page 7.

## MAINTENANCE

Observing regular maintenance intervals helps ensure that you get maximum performance and life from your pressure washer.

There is a break-in period for the pump. After changing the oil after the pump's break-in period, the interval between required changes is longer.

If you are operating in dusty conditions, these maintenance checks should be made more often.

INTERVAL	WHAT TO DO
Daily	Clean water inlet screen. Check pump oil level. Fill as necessary.
After first 50 hours of operation.	Change pump break-in oil. Use SAE 20W or 30W non-detergent oil.
Each 500 hours of operation or 3 months.	Change pump oil. Use SAE 20W or 30W non-detergent oil.

	OIL CAPACITY	TYPE
Pump	10.1 Oz. (.3 liters)	SAE 20W or 30W Non-Detergent

## TROUBLESHOOTING CHART

### WARNING

To reduce the risk of serious bodily injury, including fluid injection, splashing in the eyes or on the skin, or injury from moving parts, always follow the **Pressure Relief Procedure Warning** on page 7 before proceeding.

PROBLEM	CAUSE	SOLUTION
Low Pressure	Worn nozzle. Coupling slippage. Air leak in inlet plumbing.  Inlet filter clogged.  Worn packing. Abrasives in pumped fluid or severe cavitation. Inadequate water supply. Fouled or dirty inlet or discharge valves. Worn inlet or discharge valves. Leaky discharge hose. Pressure adjustment set down.	Replace with nozzle of proper size. Tighten or replace. Disassemble, reseal, replace bad parts, and reassemble. Clean. Use adequate size. Check more frequently. Install proper filter. Check flow available to pump. Replace packings.  Clean inlet and discharge valve assemblies.  Replace worn valves and/or discharge hose.  Turn adjustment knob in to increase pressure.
Pump runs extremely rough, pressure low.	Restricted inlet or air entering the inlet plumbing. Inlet restrictions and/or air leaks. Stuck inlet or discharge valve. Leaking high pressure seals. Inadequate water supply.	Proper size inlet plumbing; check for air tight seal. Clean out foreign material, replace worn valves.  Replace seals. Check flow available to pump.
Water leakage from under the manifold.	Worn packings.	Replace packings.
Water in pump crankcase.	Worn packings. Oil seal leaking. May be caused by humid air condensing into water inside the crankcase.	Replace packings. Replace oil seats. Change oil at 3 month or 500 hour intervals.
Frequent or premature failure of the packing.	Scored, damaged, or worn plungers. Abrasive material in the water being pumped. Inlet water temperature too high. Over pressurizing pump.  Excessive pressure due to partially plugged or damaged tip. Pump running too long without spraying or cleaning. Running pump dry.	Replace plungers.  Install proper inlet filter.  Check inlet water temperature; be sure not to exceed 160°F. Do not modify any factory-set adjustments. Clean or replace tip.  Never run pump more than 10 minutes without spraying or cleaning. Do not run pump without water.
Strong surging at the inlet and low pressure on the discharge side.	Foreign particles in the inlet or discharge valve, or worn inlet and/or discharge valves.	Replace or clean valves.
Unit will not start.	Unit not plugged in. G.F.I.C. activated.  Electric motor overheated.  Electric service off.	Check power cord. Check for proper grounding. Push switch ON (RESET) button. Let motor cool and push reset button on motor. Check fuse/circuit breaker panel.
Chemical injection system doesn't work.	Chemical injector clogged.  Adjustable nozzle completely closed. Low chemical level.	Disassemble chemical valve and clean. Check and clean chemical hose and filter. Turn control ring on nozzle clockwise to cause drop in pressure. Check level of chemical.



## PUMP SERVICE

### WARNING

To reduce the risk of serious bodily injury, including fluid injection, splashing in the eyes or on the skin, or injury from moving parts, always follow the **Pressure Relief Procedure Warning** on page 7 before proceeding.

**NOTE:** The following metric wrenches are needed: M6, M10, M30 Allen wrenches.

A pump repair tool kit, P/N 800-271, is available. It includes packing, extraction and insertion tools.

Repair kits are available. Refer to the individual repair sections, and the parts page for more details. For the best results, use all the parts in the kit.

### Valves

#### NOTE:

To replace valves, order kit part no. 801-472.

1. Remove the hex plug (205) from the manifold (206) using an M30 wrench.
2. Examine the o-ring (204) under the plug and replace it if it is cut or distorted.
3. Remove the valve assembly (203) from the cavity; the assembly may come apart.
4. Install a new valve (203). Install the o-ring (204) and plug (205) and torque to 75 ft-lb (10.3 Nm).

#### NOTE:

Retorque the plug after 5 hours of operation.

2. Carefully pull the packing retainer (212) from the manifold. Examine the o-ring (213) and replace it if it is cut or damaged.
3. Remove the v-packing (210) and head ring (209). Pull out the intermediate retainer ring (211). Remove the v-packing (210) and head ring (209).
4. Inspect all parts and replace as necessary.
5. Thoroughly clean the packing cavities and examine.
6. Lightly grease the packing cavities and then replace the packings in the following order: head ring (209), v-packing (210), intermediate ring (211), head ring (209), packing (210), and packing retainer (212), with the o-ring (213) installed into the retainer groove.

### Pumping Section

1. Remove the six Allen head cap screws (201) and lockwasher (202) from the manifold (206) using a M6 Allen wrench.
2. Carefully separate the manifold from the crankcase. It may be necessary to tap the manifold lightly with a rubber mallet.

### CAUTION

To avoid damaging the plungers or seals, keep the manifold properly aligned with the ceramic plungers when removing it.

3. Carefully examine each plunger (219) and replace it if there is any scoring.

### Servicing The V-Packings

#### NOTE:

To replace just the v-packings, use kit part no. 801-662 which will service the entire pump.

To replace the v-packings, rings and retainers, order two of kit part no. 801-664 to service the entire pump.

1. If the manifold is not already removed, follow Steps 1 and 2 of pumping section.

### CAUTION

Be very sure the parts are installed in the proper order and facing the correct direction. See Figure 4. Improperly installed parts will cause a malfunction.

7. Reassemble the manifold as instructed in Steps 7 and 8 of Servicing The Plungers.

### Servicing The Plungers

#### NOTE:

Plunger repair kit, part no. 801-474, is available to service all the plungers.

1. Loosen the plunger retaining screws (215), 5 to 6 turns, using an M10 wrench. Push the plunger (219) toward the crankcase to separate the plunger and retaining screw.
2. Remove the screw (215) from the plunger and examine the o-ring (217), backup ring (218) and copper bearing/gasket washer (216). Replace these parts, if necessary, using kit part no. 801-474.
3. Remove the plunger (219) and flinger (220) from the plunger shaft. Clean, examine and replace parts as necessary.

4. Inspect the plunger shaft for oil leakage from the crankcase. If leaking is obvious, replace the oil seals (214). Otherwise, DO NOT remove these seals as they cannot be reused.

**NOTE:**

Oil Seal Kit, part no. 801-658, is available to replace both seals.

5. Lightly grease the oil seal (if it is being replaced) and the flinger, and replace them on the plunger shaft. Then install the plunger.
6. Lightly grease the retaining screw (215) and the outer end of the plunger. Place the washer (216), o-ring (217) and backup ring (218) around the screw and install the screw through the plunger. Torque to 14.4 ft-lb (2 Nm).

**NOTE:**

If you plan to replace the packings, go to Servicing the V-Packings.

7. Lubricate the outside of each plunger. Slide the manifold onto the crankcase, being careful not to damage the seals.

8. Install the six Allen head cap screws (201) and washers (202) finger tight. Torque the screws to 15.9 ft-lb (2.2 Nm) following the tightening pattern in Figure 3. Uneven tightening may cause the manifold to bind or jam.

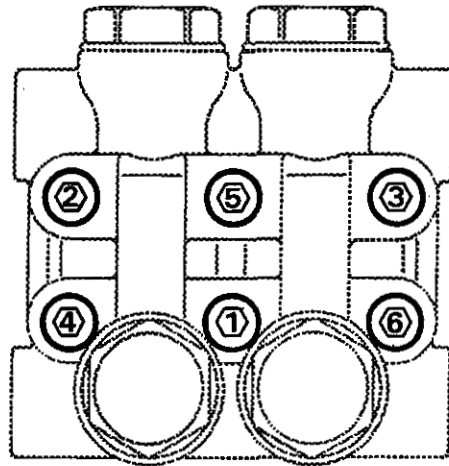

FIGURE 3

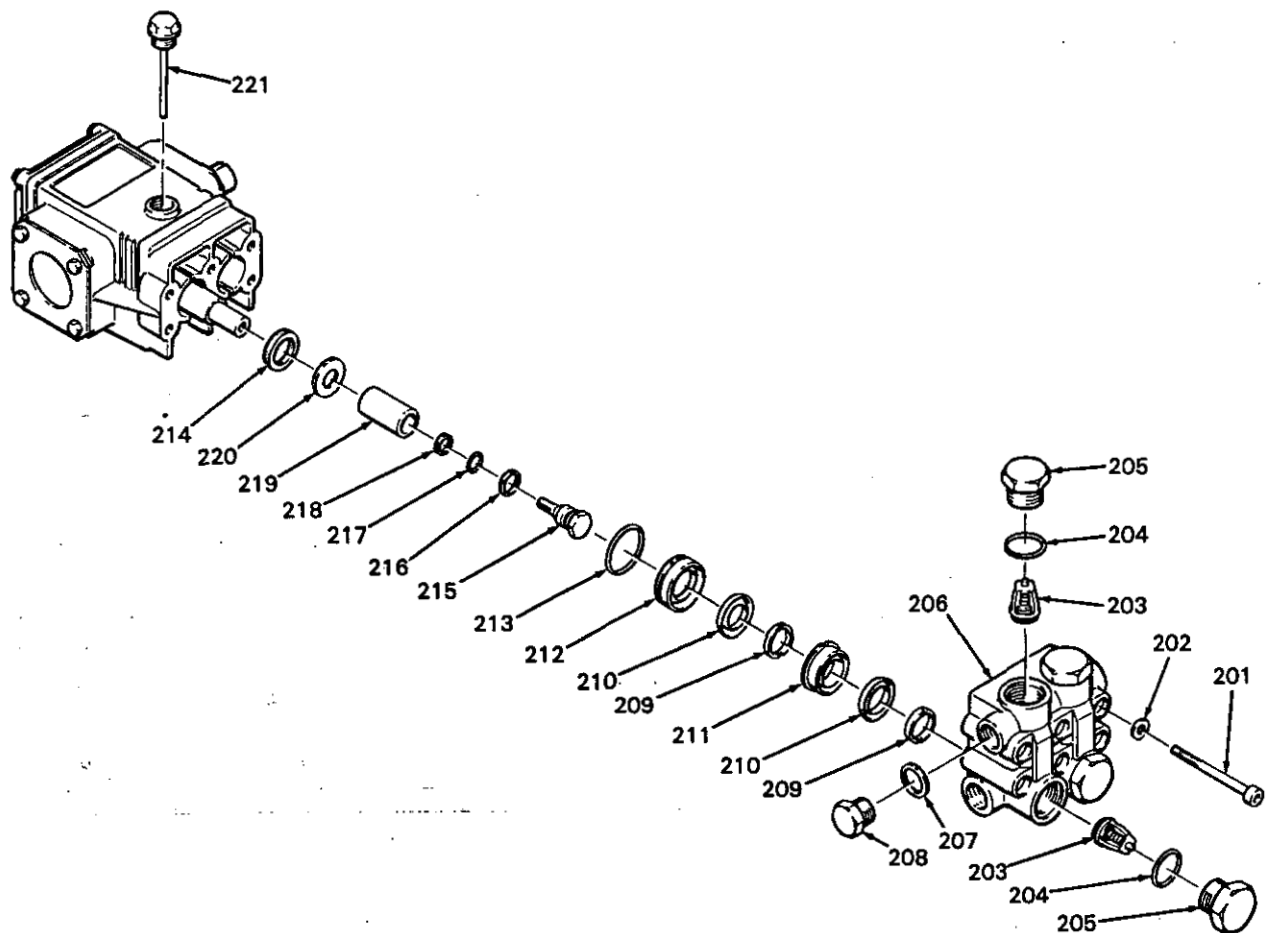
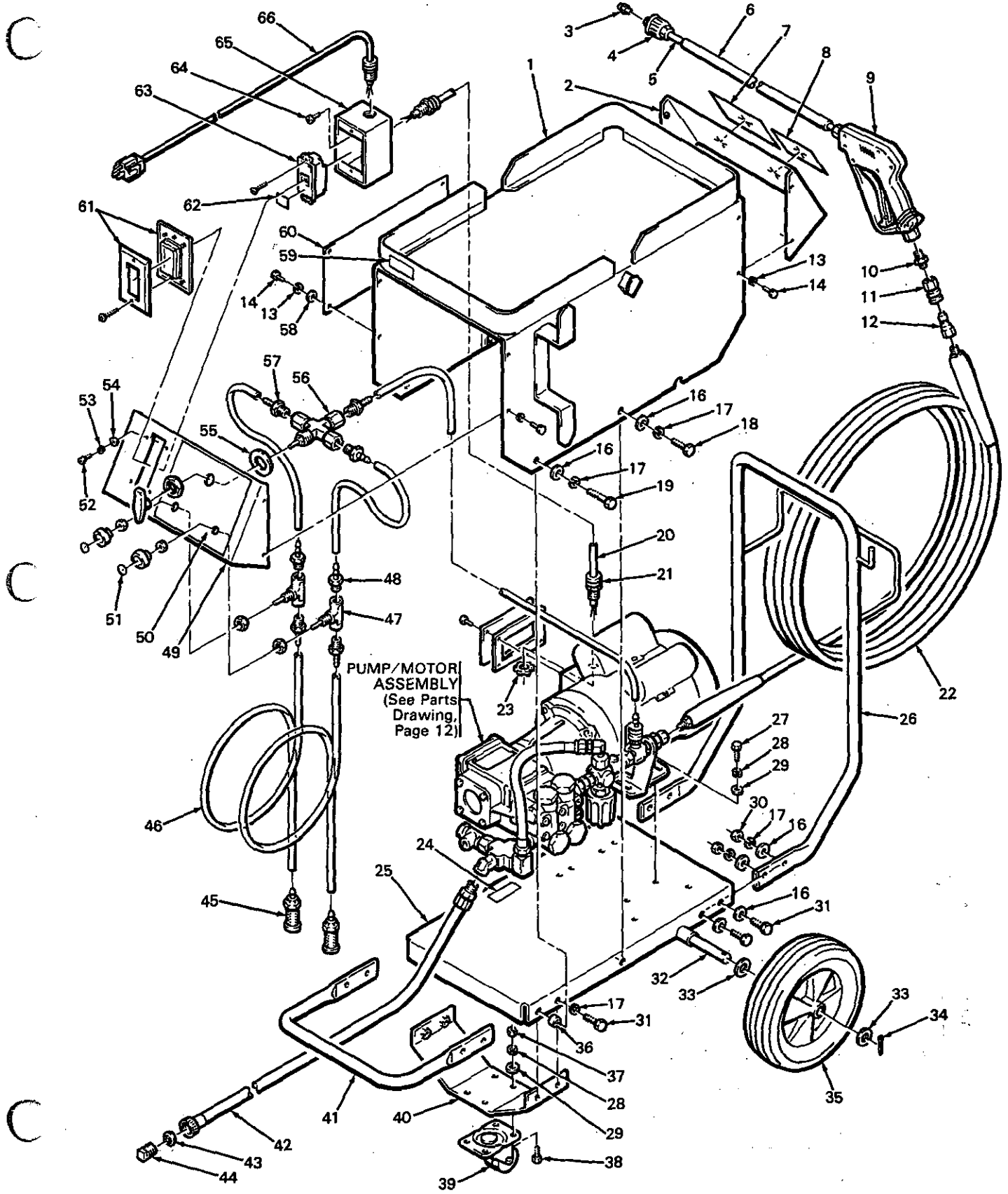

FIGURE 4

**PARTS DRAWING**  
**DuBois 826,**  
**P/N 800-232**



(Continued)

**PARTS DRAWING**  
DuBois 826, (Continued)

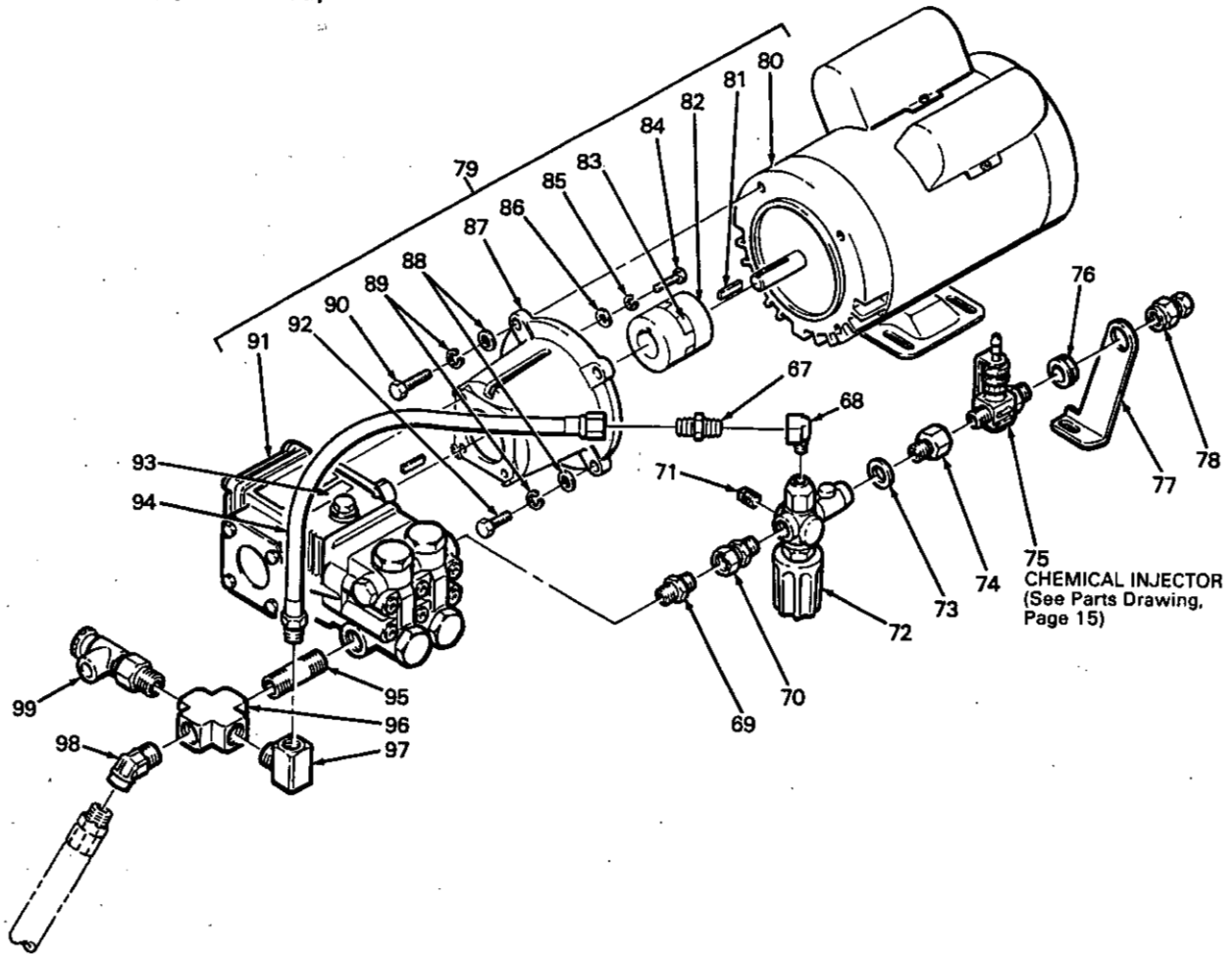

**WIRING DIAGRAM**

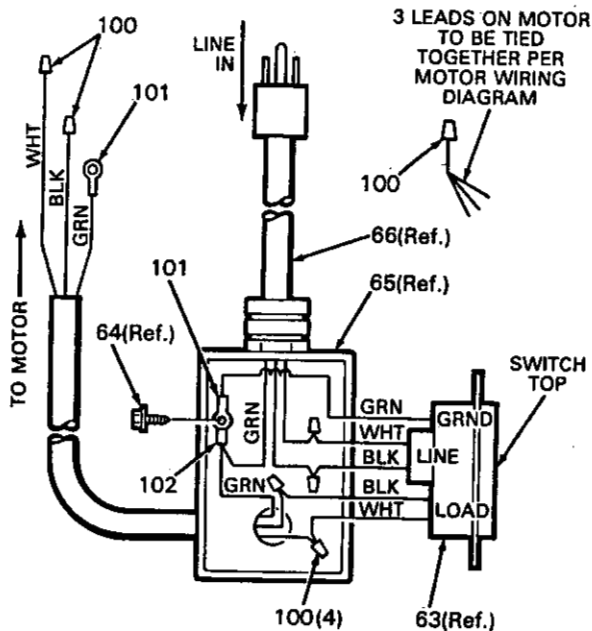

**PARTS LIST**  
DuBois 826, 800-232

REF. NO.	PART NO.	DESCRIPTION	QTY.
1	802-664	HOOD	1
2	802-637	PANEL, End	1
3	801-666	TIP, 1506	1
4	800-118	NOZZLE, Adjustable	1
5	801-935	WAND	1
6	801-957	SLEEVE, Safety	1
7	801-129	LABEL, Warning	1
8	801-388	LABEL, Warning, Ground	1
9	802-699	GUN	1
10	801-103	NIPPLE, 3/8 x 1/4	1
11	801-009	QUICK COUPLE, Female	1
12	801-090	QUICK COUPLE, Male	1
13	801-875	LOCK, #10	10
14	801-605	SCREW, 10-24 x 3/4	10
16	801-015	FLAT, 5/16	12
17	801-363	LOCK, 3/8	10
18	801-546	BOLT, 3/8-16 x 1-1/4	2
19	801-214	BOLT, 3/8-16 x 1-3/4	2
20	802-704	CORD	36"
21	801-931	GRIP, Cord	3
22	801-967	HOSE, H.P., 30'	1

(Continued)

**PARTS LIST**  
**DuBois 826, 800-232 (Continued)**

REF. PART NO.	REF. PART NO.	DESCRIPTION	QTY.	REF. PART NO.	REF. PART NO.	DESCRIPTION	QTY.
23	801-937	LOCKNUT, 1/2	1	66	801-966	CORD, W/Plug	1
24	801-501	LABEL, Serial No.	1	67	802-627	ADAPTOR (Included with Hose 801-866)	1
25	800-246	CHASSIS	1	68	801-620	ELBOW, Street, 1/4 x 90°	1
26	802-729	HANDLE	1	69	801-891	COUPLING, 3/8-M x 3/8-M	1
27	801-941	BOLT, 5/16-18 x 1	4	70	801-890	COUPLING, 3/8-M x 3/8-F	1
28	801-025	LOCK, 5/16	8	71	801-709	PLUG, 1/4	1
29	801-023	FLAT, 1/4	8	72	801-865	UNLOADER, Replacement	1
30	801-878	NUT, 3/8-16	4	73	801-907	WASHER, Aluminum	1
31	801-818	BOLT, 3/8-16 x 1	6	74	801-905	ADAPTOR, 3/8-FXG3/8B-M	1
32	801-857	AXLE	1	75	800-138	INJECTOR, Chemical	1
33	801-235	FLAT, 5/8	4	76	801-900	GROMMET	1
34	801-880	PIN, Cotter	2	77	801-901	SUPPORT, Unloader	1
35	801-879	WHEEL	2	78	801-881	COUPLING, 3/8F x 1/4-F	1
36	802-648	PIVOT	2	79	800-154	PUMP/MOTOR (Includes Ref. No's. 80-92)	1
37	801-024	NUT, 5/16-18	4	80	802-297	MOTOR, 1.5 hp, "C" Face (Includes Ref. No. 81)	1
38	801-940	BOLT, 5/16-18 x 3/4	4	81	802-782	KEY	1
39	802-703	CASTER	1	82	801-871	COUPLER (Includes Ref. No. 83)	1
40	800-247	BRACKET, Caster	1	83	801-887	SPIDER	1
41	802-730	BUMPER	1	84	801-872	BOLT, Hex Hd., M6 x 20 mm	4
42	802-735	HOSE, Inlet	1	85	801-139	WASHER, Lock, 1/4	4
43	801-112	FILTER/WASHER	1	86	801-023	WASHER, Flat, 1/4	4
44	801-910	PLUG	1	87	801-870	COUPLER HOUSING	1
45	801-683	STRAINER, Chemical	2	88	801-015	WASHER, Flat, 5/16	4
46	801-813	TUBING, 1/4 ID	16'	89	801-363	WASHER, Lock, 5/16	4
47	802-683	VALVE, Metering	2	90	801-546	BOLT, Hex hd., 3/8-16 x 1-1/4	2
48	802-669	HOSE BARB, 1/8 x 1/4	2	91	801-864	PUMP, T-9791 (See Parts Drawing, page 14)	1
49	802-636	PANEL, End, Control	1	92	801-818	BOLT, Hex Hd., 3/8-16 x 1	2
50	802-686	LABEL, Control Panel	1	93	801-524	LABEL, Pump	1
51	802-843	LABEL, Knob	2	94	801-866	HOSE, By-Pass (Includes 802-627 Adaptor)	1
52	802-733	SCREW, 6-32 x 1/2	4	95	801-523	NIPPLE, 1/2 x 2	1
53	802-731	LOCK, #6	4	96	801-622	CROSS, 1/2	1
54	802-732	FLAT, #6	4	97	801-178	ELBOW, Street, 1/2 x 90°	1
55	801-547	FLAT, 3/4	1	98	802-665	ELBOW, Street, 1/2 x 45°	1
56	802-684	VALVE, 3-Way	1	99	800-115	VALVE, Relief, Temp	1
57	801-733	HOSE BARB, 1/4 x 1/4	3	100	801-226	WIRE NUT, Orange	7
58	802-292	FLAT, #10	4	101	801-304	CONNECTOR, Crimp	2
59	801-417	LABEL, Relieve Pressure	1	102	801-221	CONNECTOR, Crimp	1
60	802-685	LABEL, Instruction	1				
61	802-027	KIT, Cover	1				
62	801-903	LABEL, Start/Stop	1				
63	801-884	SWITCH, GFI	1				
64	801-894	SCREW, Ground	1				
65	801-893	BOX, Switch	1				

See below for "How To Order Replacement Parts".

**HOW TO ORDER REPLACEMENT PARTS**

1. To be sure you receive the correct replacement parts, kit or accessories, always give all of the information requested in the chart below.
2. Check the parts list to identify the correct part number; *do not use the ref. no. when ordering.*
3. Order all parts from your nearest Graco distributor.

6 digit PART NUMBER	QTY	PART DESCRIPTION

**PARTS DRAWING**  
**Pump, 801-864**

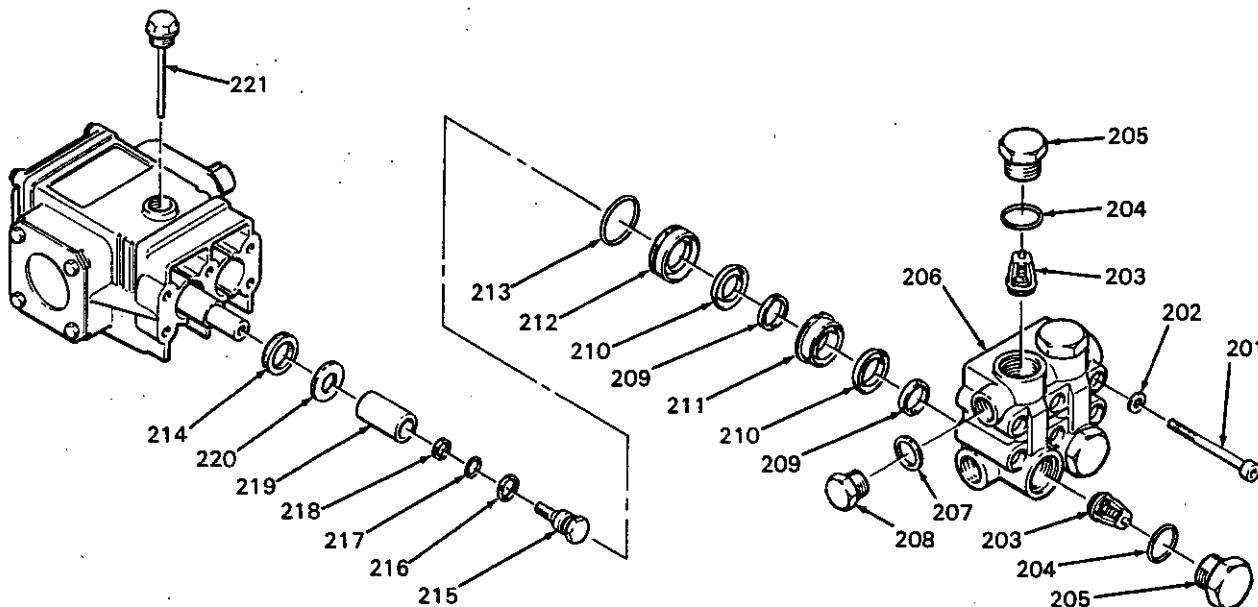

**PARTS LIST**  
**Pump, 801-864**

REF. PART NO.	NO.	DESCRIPTION	QTY.
201	801-651	SCREW, M8	6
202	801-652	WASHER	6
† 203		VALVE	4
‡ 204	801-470	O-RING	4
‡ 205		PLUG	4
206	802-795	MANIFOLD	1
207	801-485	WASHER	1
208	801-484	CAP, G 3/8 BSP	1
*209		HEAD RING	4
†*210		PACKING	4
*211		INTERMEDIATE RING	2
*212		RETAINER, Packing	2
*213		O-RING	2
***214		OIL SEAL	2
**215		SCREW, Retainer	2
**216		WASHER	2
**217		O-RING	2
**218		BACK-UP RING	2
219	801-661	PLUNGER	2
220	801-660	FLINGER	2
221	801-659	DIPSTICK	1

See page 13 for "How To Order Replacement Parts".

**REPAIR KITS**

<p>***  <b>OIL SEAL KIT 801-658</b>            Includes:            REF. NO. QTY.            214 3</p>	<p>†  <b>PACKING KIT 801-662</b>            Includes:            REF. NO. QTY.            210 6</p>
<p>† †  <b>VALVE KIT 801-472</b>            Includes:            REF. NO. QTY.            203 6</p>	<p>‡  <b>VALVE PLUG KIT 802-306</b>            Includes:            REF. NO. QTY.            204 6            205 6</p>
<p>*  <b>PACKING &amp; RETAINER KIT 801-664</b>            (Two kits needed for entire pump)            Includes:            REF. NO. QTY.            209 1            210 1            211 1            212 1            213 1</p>	<p>**  <b>PLUNGER REPAIR KIT 801-474</b>            Includes:            REF. NO. QTY.            215 3            216 3            217 3            218 3</p>

**NOTE**

Most repair kits for this pump will have extra parts because they are also standard kits for other pumps. Keep extra parts for future use.

**PARTS DRAWING**  
Chemical Injector, 800-138

**PARTS LIST**  
Chemical Injector, 800-138

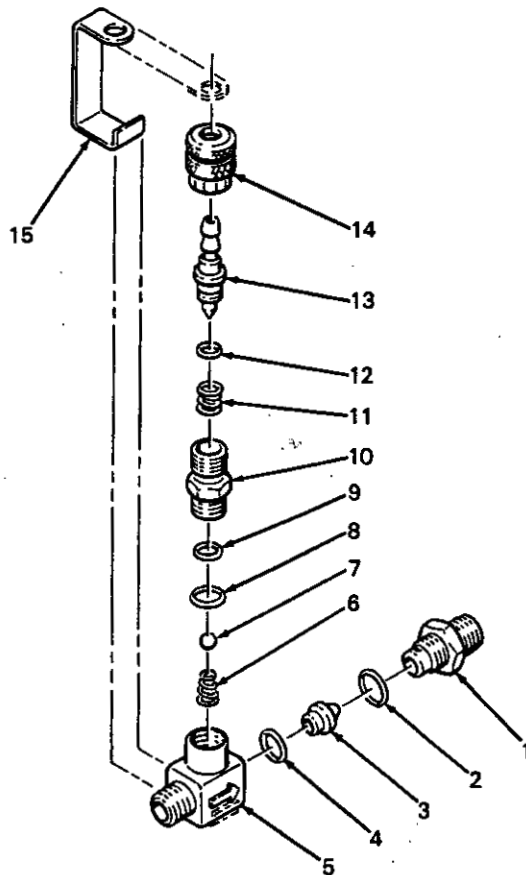

REF. PART NO.	DESCRIPTION	QTY.
1 801-684	NIPPLE, Hex, brass, 3/8 NPT	1
2 801-685	O-RING	1
3 801-687	NOZZLE NO. 2	1
4 801-688	O-RING	1
5 801-689	CHEMJET BODY	1
6 801-690	SPRING, cone	1
7 801-784	BALL, SST	1
8 801-692	O-RING	1
9 801-693	O-RING	1
10 801-694	VALVE SEAT	1
11 801-695	SPRING	1
12 801-696	O-RING	1
*13 801-697	NEEDLE/HOSE BARB	1
14 801-698	ADJUSTMENT KNOB	1
15 801-682	SPRING, retaining	1

\*If an extremely harsh chemical is to be injected, or if corrosion problems exist, the standard brass needle/hose barb (Ref. No. 13) may be replaced with a stainless steel needle/hose barb, Part No. 801-969.

See page 13 for "How To Order Replacement Parts".

**TECHNICAL DATA**

MOTOR: 1.5 hp, single phase 115 V, 60 Hz, 15 Amp, TEFC

WATER PUMP: 800 psi (55 bar) measured at pump  
2.6 GPM (9.8 liter/min)

WETTED PARTS: High Pressure Hose: Acrylonitrile and Buna-N cover and tube  
Bypass Hose: Synthetic yarn, EPDM  
Pressure Washer (including fitting): Anodized Aluminum, Aluminum or Bronze alloys, Brass, Copper, Nylon-PTFE composite, Ceramic, Buna-N, Cotton, 316, 303, & 304 Stainless Steel, Polyamide-12 Thermo-plastic, TPTFE Carbon Steel, zinc or yellow chromate plate

UNIT WEIGHT: 100 lb. (46 kg)

OVERALL DIMENSION: Length: 38 in. (965 mm)  
Width: 19 in. (482 mm)  
Height: 33 in. (838 mm)

MAX. INLET WATER TEMPERATURE: 160°F (70° C)

INLET HOSE CONNECTION: 3/4" garden hose (f)

PUMP OIL CAPACITY: 10.1 oz. (.3 liters)

\*PTFE is a registered trademark of the DuPont Company

## THE GRACO WARRANTY

### WARRANTY

Graco warrants all equipment manufactured by it and bearing its name to be free from defects in material and workmanship on the date of sale by an authorized Graco distributor to the original purchaser for use. As purchaser's sole remedy for breach of this warranty, Graco will, for a period of twelve months from the date of sale, repair or replace any part of the equipment proven defective. This warranty applies only when the equipment is installed, operated and maintained in accordance with Graco's written recommendations.

This warranty does not cover, and Graco shall not be liable for, any malfunction, damage or wear caused by faulty installation, misapplication, abrasion, corrosion, inadequate or improper maintenance, negligence, accident, tampering, or substitution of non-Graco component parts. Nor shall Graco be liable for malfunction, damage or wear caused by the incompatibility with Graco equipment of structures, accessories, equipment or materials not supplied by Graco, or the improper design, manufacture, installation, operation or maintenance of structures, accessories, equipment or materials not supplied by Graco.

This warranty is conditioned upon the prepaid return of the equipment claimed to be defective for examination by Graco to verify the claimed defect. If the claimed defect is verified, Graco will repair or replace free of charge any defective parts. The equipment will be returned to the original purchaser transportation prepaid. If inspection of the equipment does not disclose any defect in material or workmanship, repairs will be made at a reasonable charge, which charges may include the costs of parts, labor and transportation.

### DISCLAIMERS AND LIMITATIONS

THE TERMS OF THIS WARRANTY CONSTITUTE PURCHASER'S SOLE AND EXCLUSIVE REMEDY AND ARE IN LIEU OF ANY OTHER WARRANTIES (EXPRESS OR IMPLIED), INCLUDING WARRANTY OF MERCHANTABILITY OR WARRANTY OF FITNESS FOR A PARTICULAR PURPOSE, AND OF ANY NON-CONTRACTUAL LIABILITIES, INCLUDING PRODUCT LIABILITIES, BASED ON NEGLIGENCE OR STRICT LIABILITY. EVERY FORM OF LIABILITY FOR DIRECT, SPECIAL OR CONSEQUENTIAL DAMAGES OR LOSS IS EXPRESSLY EXCLUDED AND DENIED. IN NO CASE SHALL GRACO'S LIABILITY EXCEED THE AMOUNT OF THE PURCHASE PRICE. ANY ACTION FOR BREACH OF WARRANTY MUST BE BROUGHT WITHIN TWO (2) YEARS OF THE DATE OF SALE.

### EQUIPMENT NOT COVERED BY GRACO WARRANTY

GRACO MAKES NO WARRANTY, AND DISCLAIMS ALL IMPLIED WARRANTIES OF MERCHANTABILITY AND FITNESS FOR A PARTICULAR PURPOSE, WITH RESPECT TO ACCESSORIES, EQUIPMENT, MATERIALS, OR COMPONENTS SOLD BUT NOT MANUFACTURED BY GRACO. These items sold, but not manufactured by Graco (such as electric motor, switches, hose, etc.), are subject to the warranty, if any, of their manufacturer. Graco will provide purchaser with reasonable assistance in making any claim for breach of these warranties.

**Factory Branches:** Atlanta, Dallas, Detroit, Los Angeles, West Caldwell (N.J.)  
**Subsidiary and Affiliate Companies:** Canada; England; Switzerland; France; Germany; Hong Kong; Japan  
**GRACO INC. P.O. BOX 1441 MINNEAPOLIS, MN 55440-1444**

PRINTED IN U.S.A. 802-776 6/87